

(12) INTERNATIONAL APPLICATION PUBLISHED UNDER THE PATENT COOPERATION TREATY (PCT)

(19) World Intellectual Property
Organization
International Bureau



(43) International Publication Date
5 February 2004 (05.02.2004)

PCT

(10) International Publication Number
WO 2004/011776 A2

- (51) International Patent Classification⁷: E21D (74) Agents: MATTINGLY, Todd et al.; Haynes and Boone, LLP, Suite 4300, 1000 Louisiana Street, Houston, TX 77002-5012 (US).
- (21) International Application Number: PCT/US2003/020870 (81) Designated States (*national*): AE, AG, AI, AM, AT, AU, AZ, BA, BB, BG, BR, BY, BZ, CA, CH, CN, CO, CR, CU, CZ, DE, DK, DM, DZ, EC, EE, ES, FI, GB, GD, GE, GH, GM, HR, HU, ID, IL, IN, IS, JP, KE, KG, KP, KR, KZ, LC, LK, LR, LS, LT, LU, LV, MA, MD, MG, MK, MN, MW, MX, MZ, NO, NZ, OM, PH, PL, PT, RO, RU, SC, SD, SE, SG, SK, SL, TJ, TM, TN, TR, TT, TZ, UA, UG, US, UZ, VC, VN, YU, ZA, ZM, ZW.
- (22) International Filing Date: 2 July 2003 (02.07.2003) (84) Designated States (*regional*): ARIPO patent (GH, GM, KE, LS, MW, MZ, SD, SI, SZ, TZ, UG, ZM, ZW), Eurasian patent (AM, AZ, BY, KG, KZ, MD, RU, TJ, TM), European patent (AT, BE, BG, CH, CY, CZ, DE, DK, EE, ES, FI, FR, GB, GR, HU, IE, IT, LU, MC, NL, PT, RO, SE, SI, SK, TR), OAPI patent (BF, BJ, CF, CG, CI, CM, GA, GN, GQ, GW, ML, MR, NE, SN, TD, TG).
- (25) Filing Language: English
- (26) Publication Language: English
- (30) Priority Data: 60/399,240 29 July 2002 (29.07.2002) US
- (71) Applicant (*for all designated States except US*): ENVENTURE GLOBAL TECHNOLOGY [US/US]; 16200 A. Park Row, Houston, TX 77084 (US).
- (72) Inventor; and
- (75) Inventor/Applicant (*for US only*): COOK, Robert, Lance [US/US]; 934 Caswell Court, Katy, TX 77450 (US).

[Continued on next page]

(54) Title: METHOD OF FORMING A MONO DIAMETER WELLBORE CASING

(57) Abstract: A method of forming a mono diameter wellbore casing.



WO 2004/011776 A2

12

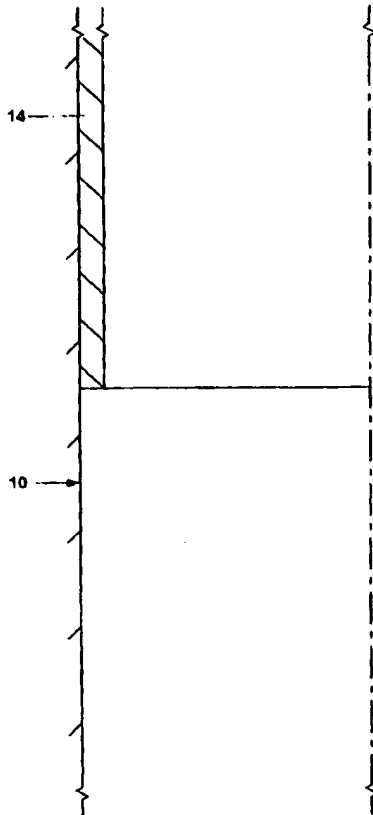



Declaration under Rule 4.17:

— *of inventorship (Rule 4.17(iv)) for US only*

Published:

— *without international search report and to be republished upon receipt of that report*

For two-letter codes and other abbreviations, refer to the "Guidance Notes on Codes and Abbreviations" appearing at the beginning of each regular issue of the PCT Gazette.

METHOD OF FORMING A MONO DIAMETER WELLBORE CASING**Cross Reference To Related Applications**

[001] The present application claims the benefit of the filing dates of (1) U.S. provisional patent application serial no. 60/399,240, attorney docket no 25791.111, filed on 7/29/2002, , the disclosure of which is incorporated herein by reference.

[002] The present application is related to the following: (1) U.S. patent application serial no. 09/454,139, attorney docket no. 25791.03.02, filed on 12/3/1999, (2) U.S. patent application serial no. 09/510,913, attorney docket no. 25791.7.02, filed on 2/23/2000, (3) U.S. patent application serial no. 09/502,350, attorney docket no. 25791.8.02, filed on 2/10/2000, (4) U.S. patent no. 6,328,113, (5) U.S. patent application serial no. 09/523,460, attorney docket no. 25791.11.02, filed on 3/10/2000, (6) U.S. patent application serial no. 09/512,895, attorney docket no. 25791.12.02, filed on 2/24/2000, (7) U.S. patent application serial no. 09/511,941, attorney docket no. 25791.16.02, filed on 2/24/2000, (8) U.S. patent application serial no. 09/588,946, attorney docket no. 25791.17.02, filed on 6/7/2000, (9) U.S. patent application serial no. 09/559,122, attorney docket no. 25791.23.02, filed on 4/26/2000, (10) PCT patent application serial no. PCT/US00/18635, attorney docket no. 25791.25.02, filed on 7/9/2000, (11) U.S. provisional patent application serial no. 60/162,671, attorney docket no. 25791.27, filed on 11/1/1999, (12) U.S. provisional patent application serial no. 60/154,047, attorney docket no. 25791.29, filed on 9/16/1999, (13) U.S. provisional patent application serial no. 60/159,082, attorney docket no. 25791.34, filed on 10/12/1999, (14) U.S. provisional patent application serial no. 60/159,039, attorney docket no. 25791.36, filed on 10/12/1999, (15) U.S. provisional patent application serial no. 60/159,033, attorney docket no. 25791.37, filed on 10/12/1999, (16) U.S. provisional patent application serial no. 60/212,359, attorney docket no. 25791.38, filed on 6/19/2000, (17) U.S. provisional patent application serial no. 60/165,228, attorney docket no. 25791.39, filed on 11/12/1999, (18) U.S. provisional patent application serial no. 60/221,443, attorney docket no. 25791.45, filed on 7/28/2000, (19) U.S. provisional patent application serial no. 60/221,645, attorney docket no. 25791.46, filed on 7/28/2000, (20) U.S. provisional patent application serial no. 60/233,638, attorney docket no. 25791.47, filed on 9/18/2000, (21) U.S. provisional patent application serial no. 60/237,334, attorney docket no. 25791.48, filed on 10/2/2000, (22) U.S. provisional patent application serial no. 60/270,007, attorney docket no. 25791.50, filed on 2/20/2001, (23) U.S. provisional patent application serial no. 60/262,434, attorney docket no. 25791.51, filed on 1/17/2001, (24) U.S. provisional patent application serial no. 60/259,486, attorney docket no. 25791.52, filed on 1/3/2001, (25) U.S. provisional patent application serial no. 60/303,740, attorney docket no. 25791.61, filed on 7/6/2001, (26) U.S. provisional patent application serial no. 60/313,453, attorney docket no. 25791.59, filed on 8/20/2001, (27) U.S. provisional patent application serial no. 60/317,985, attorney docket no. 25791.67, filed on 9/6/2001, (28) U.S. provisional patent application serial no. 60/3318,386, attorney docket no. 25791.67.02, filed on 9/10/2001, (29) U.S. utility patent application serial no. 09/969,922, attorney docket no. 25791.69, filed on 10/3/2001, (30) U.S. utility

patent application serial no. 10/016,467, attorney docket no. 25791.70, filed on 12/10/2001, (31) U.S. provisional patent application serial no. 60/343,674, attorney docket no. 25791.68, filed on 12/27/2001, (32) U.S. provisional patent application serial no. 60/346,309, attorney docket no. 25791.92, filed on 1/7/2002, (33) U.S. provisional patent application serial no. 60/372,048, attorney docket no. 25791.93, filed on 4/12/2002, (34) U.S. provisional patent application serial no. 60/380,147, attorney docket no. 25791.104, filed on 5/6/2002, (35) U.S. provisional patent application serial no. 60/387,486, attorney docket no. 25791.107, filed on 6/10/2002, (36) U.S. provisional patent application serial no. 60/387,961, attorney docket no. 25791.108, filed on 6/12/2002, (37) U.S. provisional patent application serial no. 60/391,703, attorney docket no. 25791.90, filed on 6/26/2002, (38) U.S. provisional patent application serial no. 60/397,284, attorney docket no. 25791.106, filed on 7/19/2002, and (39) U.S. provisional patent application serial no. 60/398,061, attorney docket no. 25791.110, filed on 7/24/2002, the disclosures of which are incorporated herein by reference.

Background of the Invention

[003] This invention relates generally to oil and gas exploration, and in particular to forming and repairing wellbore casings to facilitate oil and gas exploration.

[004] Conventionally, when a wellbore is created, a number of casings are installed in the borehole to prevent collapse of the borehole wall and to prevent undesired outflow of drilling fluid into the formation or inflow of fluid from the formation into the borehole. The borehole is drilled in intervals whereby a casing which is to be installed in a lower borehole interval is lowered through a previously installed casing of an upper borehole interval. As a consequence of this procedure the casing of the lower interval is of smaller diameter than the casing of the upper interval. Thus, the casings are in a nested arrangement with casing diameters decreasing in downward direction. Cement annuli are provided between the outer surfaces of the casings and the borehole wall to seal the casings from the borehole wall. As a consequence of this nested arrangement a relatively large borehole diameter is required at the upper part of the wellbore. Such a large borehole diameter involves increased costs due to heavy casing handling equipment, large drill bits and increased volumes of drilling fluid and drill cuttings. Moreover, increased drilling rig time is involved due to required cement pumping, cement hardening, required equipment changes due to large variations in hole diameters drilled in the course of the well, and the large volume of cuttings drilled and removed.

[005] The present invention is directed to overcoming one or more of the limitations of the existing procedures for forming new sections of casing in a wellbore.

Summary of the Invention

[006] According to one aspect of the present invention, a method of forming a wellbore casing within a borehole that traverses a subterranean formation is provided that includes positioning a first wellbore casing within and coupling the first wellbore casing to the borehole, positioning a second wellbore casing within the borehole that overlaps with and is coupled to the first wellbore casing,

positioning a tubular liner within the borehole that overlaps with and is coupled to at least a portion of the second wellbore casing, extending the length of the borehole, decoupling the tubular liner from the second wellbore casing and removing the tubular liner from the borehole, and positioning a third wellbore casing within the borehole that overlaps with and is coupled to the second wellbore casing.

[007] According to another aspect of the present invention, a system for forming a wellbore casing within a borehole that traverses a subterranean formation is provided that includes means for positioning a first wellbore casing within and coupling the first wellbore casing to the borehole, means for positioning a second wellbore casing within the borehole that overlaps with and is coupled to the first wellbore casing, means for positioning a tubular liner within the borehole that overlaps with and is coupled to at least a portion of the second wellbore casing, means for extending the length of the borehole, means for decoupling the tubular liner from the second wellbore casing and removing the tubular liner from the borehole, and means for positioning a third wellbore casing within the borehole that overlaps with and is coupled to the second wellbore casing.

Brief Description of the Drawings

[008] FIG. 1 is a fragmentary cross-sectional illustration of the placement of a first wellbore casing within a borehole that traverses a subterranean formation.

[009] Fig. 2 is a fragmentary cross-sectional illustration of the apparatus of Fig. 1 after placing a second wellbore casing within the borehole that overlaps with a portion of the first wellbore casing.

[0010] Fig. 3 is a fragmentary cross-sectional illustration of the apparatus of Fig. 2 after radially expanding and plastically deforming the overlapping portions of the first and second wellbore casings and the remaining portion of the second wellbore casing.

[0011] Fig. 4 is a fragmentary cross-sectional illustration of the apparatus of Fig. 3 after placing a temporary tubular liner within the second wellbore casing.

[0012] Fig. 5 is a fragmentary cross sectional of the apparatus of Fig. 4 after extending the length of the borehole.

[0013] Fig. 6 is a fragmentary cross-sectional illustration of the apparatus of Fig. 5 after removing the temporary tubular liner from the borehole.

[0014] Fig. 7 is a fragmentary cross sectional illustration of the apparatus of Fig. 6 after placing a third wellbore casing that overlaps with a portion of the second wellbore casing.

Detailed Description of the Illustrative Embodiments

[0015] Referring to Fig. 1, a borehole 10 that traverses a subterranean formation 12 includes a first wellbore casing 14 that is positioned within and coupled to the borehole. In several exemplary embodiments, the first wellbore casing 14 may, for example, be positioned within and coupled to the borehole 10 using any number of conventional methods and apparatus, that may or may not include radial expansion and plastic deformation of the first wellbore casing 14, and/or using one or more of the methods and apparatus disclosed in one or more of the following: (1) U.S. patent application serial no. 09/454,139,

attorney docket no. 25791.03.02, filed on 12/3/1999, (2) U.S. patent application serial no. 09/510,913, attorney docket no. 25791.7.02, filed on 2/23/2000, (3) U.S. patent application serial no. 09/502,350, attorney docket no. 25791.8.02, filed on 2/10/2000, (4) U.S. patent no. 6,328,113, (5) U.S. patent application serial no. 09/523,460, attorney docket no. 25791.11.02, filed on 3/10/2000, (6) U.S. patent application serial no. 09/512,895, attorney docket no. 25791.12.02, filed on 2/24/2000, (7) U.S. patent application serial no. 09/511,941, attorney docket no. 25791.16.02, filed on 2/24/2000, (8) U.S. patent application serial no. 09/588,946, attorney docket no. 25791.17.02, filed on 6/7/2000, (9) U.S. patent application serial no. 09/559,122, attorney docket no. 25791.23.02, filed on 4/26/2000, (10) PCT patent application serial no. PCT/US00/18635, attorney docket no. 25791.25.02, filed on 7/9/2000, (11) U.S. provisional patent application serial no. 60/162,671, attorney docket no. 25791.27, filed on 11/1/1999, (12) U.S. provisional patent application serial no. 60/154,047, attorney docket no. 25791.29, filed on 9/16/1999, (13) U.S. provisional patent application serial no. 60/159,082, attorney docket no. 25791.34, filed on 10/12/1999, (14) U.S. provisional patent application serial no. 60/159,039, attorney docket no. 25791.36, filed on 10/12/1999, (15) U.S. provisional patent application serial no. 60/159,033, attorney docket no. 25791.37, filed on 10/12/1999, (16) U.S. provisional patent application serial no. 60/212,359, attorney docket no. 25791.38, filed on 6/19/2000, (17) U.S. provisional patent application serial no. 60/165,228, attorney docket no. 25791.39, filed on 11/12/1999, (18) U.S. provisional patent application serial no. 60/221,443, attorney docket no. 25791.45, filed on 7/28/2000, (19) U.S. provisional patent application serial no. 60/221,645, attorney docket no. 25791.46, filed on 7/28/2000, (20) U.S. provisional patent application serial no. 60/233,638, attorney docket no. 25791.47, filed on 9/18/2000, (21) U.S. provisional patent application serial no. 60/237,334, attorney docket no. 25791.48, filed on 10/2/2000, (22) U.S. provisional patent application serial no. 60/270,007, attorney docket no. 25791.50, filed on 2/20/2001, (23) U.S. provisional patent application serial no. 60/262,434, attorney docket no. 25791.51, filed on 1/17/2001, (24) U.S. provisional patent application serial no. 60/259,486, attorney docket no. 25791.52, filed on 1/3/2001, (25) U.S. provisional patent application serial no. 60/303,740, attorney docket no. 25791.61, filed on 7/6/2001, (26) U.S. provisional patent application serial no. 60/313,453, attorney docket no. 25791.59, filed on 8/20/2001, (27) U.S. provisional patent application serial no. 60/317,985, attorney docket no. 25791.67, filed on 9/6/2001, (28) U.S. provisional patent application serial no. 60/3318,386, attorney docket no. 25791.67.02, filed on 9/10/2001, (29) U.S. utility patent application serial no. 09/969,922, attorney docket no. 25791.69, filed on 10/3/2001, (30) U.S. utility patent application serial no. 10/016,467, attorney docket no. 25791.70, filed on 12/10/2001, (31) U.S. provisional patent application serial no. 60/343,674, attorney docket no. 25791.68, filed on 12/27/2001, (32) U.S. provisional patent application serial no. 60/346,309, attorney docket no. 25791.92, filed on 1/7/2002, (33) U.S. provisional patent application serial no. 60/372,048, attorney docket no. 25791.93, filed on 4/12/2002, (34) U.S. provisional patent application serial no. 60/380,147, attorney docket no. 25791.104, filed on 5/6/2002, (35) U.S. provisional patent application serial no. 60/387,486, attorney docket no. 25791.107,

filed on 6/10/2002, (36) U.S. provisional patent application serial no. 60/387,961, attorney docket no. 25791.108, filed on 6/12/2002, (37) U.S. provisional patent application serial no. 60/391,703, attorney docket no. 25791.90, filed on 6/26/2002, (38) U.S. provisional patent application serial no. 60/397,284, attorney docket no. 25791.106, filed on 7/19/2002, and (39) U.S. provisional patent application serial no. 60/398,061, attorney docket no. 25791.110, filed on 7/24/2002, the disclosures of which are incorporated herein by reference.

[0016] Referring to Fig. 2, a second wellbore casing 16 is then positioned within the borehole 10 and overlappingly coupled to a lower portion of the first wellbore casing 14. In several exemplary embodiments, the second wellbore casing 16 may, for example, be coupled to the lower portion of the first wellbore casing 14 using any number of conventional methods and apparatus, that may or may not include radial expansion and plastic deformation of the second wellbore casing 16, and/or using one or more of the methods and apparatus disclosed in one or more of the following: (1) U.S. patent application serial no. 09/454,139, attorney docket no. 25791.03.02, filed on 12/3/1999, (2) U.S. patent application serial no. 09/510,913, attorney docket no. 25791.7.02, filed on 2/23/2000, (3) U.S. patent application serial no. 09/502,350, attorney docket no. 25791.8.02, filed on 2/10/2000, (4) U.S. patent no. 6,328,113, (5) U.S. patent application serial no. 09/523,460, attorney docket no. 25791.11.02, filed on 3/10/2000, (6) U.S. patent application serial no. 09/512,895, attorney docket no. 25791.12.02, filed on 2/24/2000, (7) U.S. patent application serial no. 09/511,941, attorney docket no. 25791.16.02, filed on 2/24/2000, (8) U.S. patent application serial no. 09/588,946, attorney docket no. 25791.17.02, filed on 6/7/2000, (9) U.S. patent application serial no. 09/559,122, attorney docket no. 25791.23.02, filed on 4/26/2000, (10) PCT patent application serial no. PCT/US00/18635, attorney docket no. 25791.25.02, filed on 7/9/2000, (11) U.S. provisional patent application serial no. 60/162,671, attorney docket no. 25791.27, filed on 11/1/1999, (12) U.S. provisional patent application serial no. 60/154,047, attorney docket no. 25791.29, filed on 9/16/1999, (13) U.S. provisional patent application serial no. 60/159,082, attorney docket no. 25791.34, filed on 10/12/1999, (14) U.S. provisional patent application serial no. 60/159,039, attorney docket no. 25791.36, filed on 10/12/1999, (15) U.S. provisional patent application serial no. 60/159,033, attorney docket no. 25791.37, filed on 10/12/1999, (16) U.S. provisional patent application serial no. 60/212,359, attorney docket no. 25791.38, filed on 6/19/2000, (17) U.S. provisional patent application serial no. 60/165,228, attorney docket no. 25791.39, filed on 11/12/1999, (18) U.S. provisional patent application serial no. 60/221,443, attorney docket no. 25791.45, filed on 7/28/2000, (19) U.S. provisional patent application serial no. 60/221,645, attorney docket no. 25791.46, filed on 7/28/2000, (20) U.S. provisional patent application serial no. 60/233,638, attorney docket no. 25791.47, filed on 9/18/2000, (21) U.S. provisional patent application serial no. 60/237,334, attorney docket no. 25791.48, filed on 10/2/2000, (22) U.S. provisional patent application serial no. 60/270,007, attorney docket no. 25791.50, filed on 2/20/2001, (23) U.S. provisional patent application serial no. 60/262,434, attorney docket no. 25791.51, filed on 1/17/2001, (24) U.S. provisional patent application serial no. 60/259,486, attorney

docket no. 25791.52, filed on 1/3/2001, (25) U.S. provisional patent application serial no. 60/303,740, attorney docket no. 25791.61, filed on 7/6/2001, (26) U.S. provisional patent application serial no. 60/313,453, attorney docket no. 25791.59, filed on 8/20/2001, (27) U.S. provisional patent application serial no. 60/317,985, attorney docket no. 25791.67, filed on 9/6/2001, (28) U.S. provisional patent application serial no. 60/3318,386, attorney docket no. 25791.67.02, filed on 9/10/2001, (29) U.S. utility patent application serial no. 09/969,922, attorney docket no. 25791.69, filed on 10/3/2001, (30) U.S. utility patent application serial no. 10/016,467, attorney docket no. 25791.70, filed on 12/10/2001, (31) U.S. provisional patent application serial no. 60/343,674, attorney docket no. 25791.68, filed on 12/27/2001, (32) U.S. provisional patent application serial no. 60/346,309, attorney docket no. 25791.92, filed on 1/7/2002, (33) U.S. provisional patent application serial no. 60/372,048, attorney docket no. 25791.93, filed on 4/12/2002, (34) U.S. provisional patent application serial no. 60/380,147, attorney docket no. 25791.104, filed on 5/6/2002, (35) U.S. provisional patent application serial no. 60/387,486, attorney docket no. 25791.107, filed on 6/10/2002, (36) U.S. provisional patent application serial no. 60/387,961, attorney docket no. 25791.108, filed on 6/12/2002, (37) U.S. provisional patent application serial no. 60/391,703, attorney docket no. 25791.90, filed on 6/26/2002, (38) U.S. provisional patent application serial no. 60/397,284, attorney docket no. 25791.106, filed on 7/19/2002, and (39) U.S. provisional patent application serial no. 60/398,061, attorney docket no. 25791.110, filed on 7/24/2002, the disclosures of which are incorporated herein by reference.

[0017] Referring to Fig. 3, the overlapping portions of the first and second wellbore casings, 14 and 16, respectively, as well as the remaining portion of second wellbore casing that does not overlap with the first wellbore casing are then radially expanded and plastically deformed. As a result, in an exemplary embodiment, the inside diameters of the first wellbore casing 14 and the radially expanded and plastically deformed portion of the second wellbore casing 16 are substantially equal. In this manner, a mono diameter wellbore casing is provided that includes the first and second wellbore casings, 14 and 16, that includes a substantially constant inside diameter throughout. In several exemplary embodiments, the overlapping portions of the first and second wellbore casings, 14 and 16, respectively, as well as the remaining portion of second wellbore casing may be radially expanded and plastically deformed using, for example, conventional methods and apparatus and/or one or more of the methods and apparatus disclosed in the following: (1) U.S. patent application serial no. 09/454,139, attorney docket no. 25791.03.02, filed on 12/3/1999, (2) U.S. patent application serial no. 09/510,913, attorney docket no. 25791.7.02, filed on 2/23/2000, (3) U.S. patent application serial no. 09/502,350, attorney docket no. 25791.8.02, filed on 2/10/2000, (4) U.S. patent no. 6,328,113, (5) U.S. patent application serial no. 09/523,460, attorney docket no. 25791.11.02, filed on 3/10/2000, (6) U.S. patent application serial no. 09/512,895, attorney docket no. 25791.12.02, filed on 2/24/2000, (7) U.S. patent application serial no. 09/511,941, attorney docket no. 25791.16.02, filed on 2/24/2000, (8) U.S. patent application serial no. 09/588,946, attorney docket no. 25791.17.02, filed on 6/7/2000, (9) U.S. patent application serial no. 09/559,122, attorney docket no.

25791.23.02, filed on 4/26/2000, (10) PCT patent application serial no. PCT/US00/18635, attorney docket no. 25791.25.02, filed on 7/9/2000, (11) U.S. provisional patent application serial no. 60/162,671, attorney docket no. 25791.27, filed on 11/1/1999, (12) U.S. provisional patent application serial no. 60/154,047, attorney docket no. 25791.29, filed on 9/16/1999, (13) U.S. provisional patent application serial no. 60/159,082, attorney docket no. 25791.34, filed on 10/12/1999, (14) U.S. provisional patent application serial no. 60/159,039, attorney docket no. 25791.36, filed on 10/12/1999, (15) U.S. provisional patent application serial no. 60/159,033, attorney docket no. 25791.37, filed on 10/12/1999, (16) U.S. provisional patent application serial no. 60/212,359, attorney docket no. 25791.38, filed on 6/19/2000, (17) U.S. provisional patent application serial no. 60/165,228, attorney docket no. 25791.39, filed on 11/12/1999, (18) U.S. provisional patent application serial no. 60/221,443, attorney docket no. 25791.45, filed on 7/28/2000, (19) U.S. provisional patent application serial no. 60/221,645, attorney docket no. 25791.46, filed on 7/28/2000, (20) U.S. provisional patent application serial no. 60/233,638, attorney docket no. 25791.47, filed on 9/18/2000, (21) U.S. provisional patent application serial no. 60/237,334, attorney docket no. 25791.48, filed on 10/2/2000, (22) U.S. provisional patent application serial no. 60/270,007, attorney docket no. 25791.50, filed on 2/20/2001, (23) U.S. provisional patent application serial no. 60/262,434, attorney docket no. 25791.51, filed on 1/17/2001, (24) U.S. provisional patent application serial no. 60/259,486, attorney docket no. 25791.52, filed on 1/3/2001, (25) U.S. provisional patent application serial no. 60/303,740, attorney docket no. 25791.61, filed on 7/6/2001, (26) U.S. provisional patent application serial no. 60/313,453, attorney docket no. 25791.59, filed on 8/20/2001, (27) U.S. provisional patent application serial no. 60/317,985, attorney docket no. 25791.67, filed on 9/6/2001, (28) U.S. provisional patent application serial no. 60/3318,386, attorney docket no. 25791.67.02, filed on 9/10/2001, (29) U.S. utility patent application serial no. 09/969,922, attorney docket no. 25791.69, filed on 10/3/2001, (30) U.S. utility patent application serial no. 10/016,467, attorney docket no. 25791.70, filed on 12/10/2001, (31) U.S. provisional patent application serial no. 60/343,674, attorney docket no. 25791.68, filed on 12/27/2001, (32) U.S. provisional patent application serial no. 60/346,309, attorney docket no. 25791.92, filed on 1/7/2002, (33) U.S. provisional patent application serial no. 60/372,048, attorney docket no. 25791.93, filed on 4/12/2002, (34) U.S. provisional patent application serial no. 60/380,147, attorney docket no. 25791.104, filed on 5/6/2002, (35) U.S. provisional patent application serial no. 60/387,486, attorney docket no. 25791.107, filed on 6/10/2002, (36) U.S. provisional patent application serial no. 60/387,961, attorney docket no. 25791.108, filed on 6/12/2002, (37) U.S. provisional patent application serial no. 60/391,703, attorney docket no. 25791.90, filed on 6/26/2002, (38) U.S. provisional patent application serial no. 60/397,284, attorney docket no. 25791.106, filed on 7/19/2002, and (39) U.S. provisional patent application serial no. 60/398,061, attorney docket no. 25791.110, filed on 7/24/2002, the disclosures of which are incorporated herein by reference.

[0018] Referring to Fig. 4, a tubular liner 18 may then be positioned within and coupled to the second wellbore casing 16. In several exemplary embodiments, the tubular liner 18 may be positioned within and

coupled to the second wellbore casing 16 using any number of conventional methods and apparatus, that may or may not include radial expansion and plastic deformation of the tubular liner 18, and/or using one or more of the methods and apparatus disclosed in one or more of the following: (1) U.S. patent application serial no. 09/454,139, attorney docket no. 25791.03.02, filed on 12/3/1999, (2) U.S. patent application serial no. 09/510,913, attorney docket no. 25791.7.02, filed on 2/23/2000, (3) U.S. patent application serial no. 09/502,350, attorney docket no. 25791.8.02, filed on 2/10/2000, (4) U.S. patent no. 6,328,113, (5) U.S. patent application serial no. 09/523,460, attorney docket no. 25791.11.02, filed on 3/10/2000, (6) U.S. patent application serial no. 09/512,895, attorney docket no. 25791.12.02, filed on 2/24/2000, (7) U.S. patent application serial no. 09/511,941, attorney docket no. 25791.16.02, filed on 2/24/2000, (8) U.S. patent application serial no. 09/588,946, attorney docket no. 25791.17.02, filed on 6/7/2000, (9) U.S. patent application serial no. 09/559,122, attorney docket no. 25791.23.02, filed on 4/26/2000, (10) PCT patent application serial no. PCT/US00/18635, attorney docket no. 25791.25.02, filed on 7/9/2000, (11) U.S. provisional patent application serial no. 60/162,671, attorney docket no. 25791.27, filed on 11/1/1999, (12) U.S. provisional patent application serial no. 60/154,047, attorney docket no. 25791.29, filed on 9/16/1999, (13) U.S. provisional patent application serial no. 60/159,082, attorney docket no. 25791.34, filed on 10/12/1999, (14) U.S. provisional patent application serial no. 60/159,039, attorney docket no. 25791.36, filed on 10/12/1999, (15) U.S. provisional patent application serial no. 60/159,033, attorney docket no. 25791.37, filed on 10/12/1999, (16) U.S. provisional patent application serial no. 60/212,359, attorney docket no. 25791.38, filed on 6/19/2000, (17) U.S. provisional patent application serial no. 60/165,228, attorney docket no. 25791.39, filed on 11/12/1999, (18) U.S. provisional patent application serial no. 60/221,443, attorney docket no. 25791.45, filed on 7/28/2000, (19) U.S. provisional patent application serial no. 60/221,645, attorney docket no. 25791.46, filed on 7/28/2000, (20) U.S. provisional patent application serial no. 60/233,638, attorney docket no. 25791.47, filed on 9/18/2000, (21) U.S. provisional patent application serial no. 60/237,334, attorney docket no. 25791.48, filed on 10/2/2000, (22) U.S. provisional patent application serial no. 60/270,007, attorney docket no. 25791.50, filed on 2/20/2001, (23) U.S. provisional patent application serial no. 60/262,434, attorney docket no. 25791.51, filed on 1/17/2001, (24) U.S. provisional patent application serial no. 60/259,486, attorney docket no. 25791.52, filed on 1/3/2001, (25) U.S. provisional patent application serial no. 60/303,740, attorney docket no. 25791.61, filed on 7/6/2001, (26) U.S. provisional patent application serial no. 60/313,453, attorney docket no. 25791.59, filed on 8/20/2001, (27) U.S. provisional patent application serial no. 60/317,985, attorney docket no. 25791.67, filed on 9/6/2001, (28) U.S. provisional patent application serial no. 60/3318,386, attorney docket no. 25791.67.02, filed on 9/10/2001, (29) U.S. utility patent application serial no. 09/969,922, attorney docket no. 25791.69, filed on 10/3/2001, (30) U.S. utility patent application serial no. 10/016,467, attorney docket no. 25791.70, filed on 12/10/2001, (31) U.S. provisional patent application serial no. 60/343,674, attorney docket no. 25791.68, filed on 12/27/2001, (32) U.S. provisional patent application serial no. 60/346,309, attorney docket no. 25791.92, filed on

1/7/2002, (33) U.S. provisional patent application serial no. 60/372,048, attorney docket no. 25791.93, filed on 4/12/2002, (34) U.S. provisional patent application serial no. 60/380,147, attorney docket no. 25791.104, filed on 5/6/2002, (35) U.S. provisional patent application serial no. 60/387,486, attorney docket no. 25791.107, filed on 6/10/2002, (36) U.S. provisional patent application serial no. 60/387,961, attorney docket no. 25791.108, filed on 6/12/2002, (37) U.S. provisional patent application serial no. 60/391,703, attorney docket no. 25791.90, filed on 6/26/2002, (38) U.S. provisional patent application serial no. 60/397,284, attorney docket no. 25791.106, filed on 7/19/2002, and (39) U.S. provisional patent application serial no. 60/398,061, attorney docket no. 25791.110, filed on 7/24/2002, the disclosures of which are incorporated herein by reference.

[0019] In an exemplary embodiment, the tubular liner 18 is coupled to the entire length of the second wellbore casing 16.

[0020] Referring to Fig. 5, the length of the borehole 10 may then be extended in a conventional manner using, for example, a drilling apparatus. In an exemplary embodiment, the coupling of the tubular liner 18 to the second wellbore casing 16 reduces the risk of a collapse of the second wellbore casing during the drilling operation. In this manner, the formation of a mono diameter wellbore casing within the borehole 10 may be provide with a reduced risk of a collapse of the mono diameter wellbore casing. In an exemplary experimental implementation of the present illustrative embodiment, the collapse strength of the combination of the second wellbore casing 16 and the tubular liner 18 was about three and a half times greater than the collapse strength of the second wellbore casing 16 alone.

[0021] Referring to Fig. 6, the tubular liner 18 is then decoupled from the second wellbore casing 16 and removed from the borehole 10. In an exemplary embodiment, the tubular liner 18 may be decoupled from the second wellbore casing 16 and removed from the borehole 10 using conventional methods and apparatus.

[0022] Referring to Fig. 7, a third wellbore casing 20 is then positioned within the borehole 10 and coupled to a lower portion of the second wellbore casing 16. In several exemplary embodiments, the third wellbore casing 20 may, for example, be coupled to the lower portion of the second wellbore casing 16 using any number of conventional methods and apparatus, that may or may not include radial expansion and plastic deformation of the third wellbore casing 20, and/or using one or more of the methods and apparatus disclosed in one or more of the following: (1) U.S. patent application serial no. 09/454,139, attorney docket no. 25791.03.02, filed on 12/3/1999, (2) U.S. patent application serial no. 09/510,913, attorney docket no. 25791.7.02, filed on 2/23/2000, (3) U.S. patent application serial no. 09/502,350, attorney docket no. 25791.8.02, filed on 2/10/2000, (4) U.S. patent no. 6,328,113, (5) U.S. patent application serial no. 09/523,460, attorney docket no. 25791.11.02, filed on 3/10/2000, (6) U.S. patent application serial no. 09/512,895, attorney docket no. 25791.12.02, filed on 2/24/2000, (7) U.S. patent application serial no. 09/511,941, attorney docket no. 25791.16.02, filed on 2/24/2000, (8) U.S. patent application serial no. 09/588,946, attorney docket no. 25791.17.02, filed on 6/7/2000, (9) U.S. patent

application serial no. 09/559,122, attorney docket no. 25791.23.02, filed on 4/26/2000, (10) PCT patent application serial no. PCT/US00/18635, attorney docket no. 25791.25.02, filed on 7/9/2000, (11) U.S. provisional patent application serial no. 60/162,671, attorney docket no. 25791.27, filed on 11/1/1999, (12) U.S. provisional patent application serial no. 60/154,047, attorney docket no. 25791.29, filed on 9/16/1999, (13) U.S. provisional patent application serial no. 60/159,082, attorney docket no. 25791.34, filed on 10/12/1999, (14) U.S. provisional patent application serial no. 60/159,039, attorney docket no. 25791.36, filed on 10/12/1999, (15) U.S. provisional patent application serial no. 60/159,033, attorney docket no. 25791.37, filed on 10/12/1999, (16) U.S. provisional patent application serial no. 60/212,359, attorney docket no. 25791.38, filed on 6/19/2000, (17) U.S. provisional patent application serial no. 60/165,228, attorney docket no. 25791.39, filed on 11/12/1999, (18) U.S. provisional patent application serial no. 60/221,443, attorney docket no. 25791.45, filed on 7/28/2000, (19) U.S. provisional patent application serial no. 60/221,645, attorney docket no. 25791.46, filed on 7/28/2000, (20) U.S. provisional patent application serial no. 60/233,638, attorney docket no. 25791.47, filed on 9/18/2000, (21) U.S. provisional patent application serial no. 60/237,334, attorney docket no. 25791.48, filed on 10/2/2000, (22) U.S. provisional patent application serial no. 60/270,007, attorney docket no. 25791.50, filed on 2/20/2001, (23) U.S. provisional patent application serial no. 60/262,434, attorney docket no. 25791.51, filed on 1/17/2001, (24) U.S. provisional patent application serial no. 60/259,486, attorney docket no. 25791.52, filed on 1/3/2001, (25) U.S. provisional patent application serial no. 60/303,740, attorney docket no. 25791.61, filed on 7/6/2001, (26) U.S. provisional patent application serial no. 60/313,453, attorney docket no. 25791.59, filed on 8/20/2001, (27) U.S. provisional patent application serial no. 60/317,985, attorney docket no. 25791.67, filed on 9/6/2001, (28) U.S. provisional patent application serial no. 60/3318,386, attorney docket no. 25791.67.02, filed on 9/10/2001, (29) U.S. utility patent application serial no. 09/969,922, attorney docket no. 25791.69, filed on 10/3/2001, (30) U.S. utility patent application serial no. 10/016,467, attorney docket no. 25791.70, filed on 12/10/2001, (31) U.S. provisional patent application serial no. 60/343,674, attorney docket no. 25791.68, filed on 12/27/2001, (32) U.S. provisional patent application serial no. 60/346,309, attorney docket no. 25791.92, filed on 1/7/2002, (33) U.S. provisional patent application serial no. 60/372,048, attorney docket no. 25791.93, filed on 4/12/2002, (34) U.S. provisional patent application serial no. 60/380,147, attorney docket no. 25791.104, filed on 5/6/2002, (35) U.S. provisional patent application serial no. 60/387,486, attorney docket no. 25791.107, filed on 6/10/2002, (36) U.S. provisional patent application serial no. 60/387,961, attorney docket no. 25791.108, filed on 6/12/2002, (37) U.S. provisional patent application serial no. 60/391,703, attorney docket no. 25791.90, filed on 6/26/2002, (38) U.S. provisional patent application serial no. 60/397,284, attorney docket no. 25791.106, filed on 7/19/2002, and (39) U.S. provisional patent application serial no. 60/398,061, attorney docket no. 25791.110, filed on 7/24/2002, the disclosures of which are incorporated herein by reference.

[0023] In an exemplary embodiment, the teachings of the operational steps illustrated and described above with reference to Fig. 3 may then be repeated to provide a mono diameter wellbore casing that includes the first, second, and third wellbore casings, 14, 16, and 20, respectively. More generally, in an exemplary embodiment, the teachings of the operational steps illustrated and described above with reference to Figs. 1-7 may be repeated an indefinite number of times to provide a virtually unlimited length mono diameter wellbore casing that includes a virtually limitless number of wellbore casings.

[0024] In several alternative embodiments, the radial expansion and plastic deformation of the overlapping portions of the first and second wellbore casings, 14 and 16, and the remaining portion of the second wellbore casing is omitted.

[0025] A method of forming a wellbore casing within a borehole that traverses a subterranean formation has been described that includes positioning a first wellbore casing within and coupling the first wellbore casing to the borehole, positioning a second wellbore casing within the borehole that overlaps with and is coupled to the first wellbore casing, positioning a tubular liner within the borehole that overlaps with and is coupled to at least a portion of the second wellbore casing, extending the length of the borehole, decoupling the tubular liner from the second wellbore casing and removing the tubular liner from the borehole, and positioning a third wellbore casing within the borehole that overlaps with and is coupled to the second wellbore casing. In an exemplary embodiment, the method further includes radially expanding and plastically deforming the overlapping portions of the first and second wellbore casings, and radially expanding and plastically the portion of the second wellbore casing that does not overlap with the first wellbore casing. In an exemplary embodiment, the inside diameters of the first wellbore casing and the second wellbore casing are substantially equal. In an exemplary embodiment, the inside diameters of the first wellbore casing and the second wellbore casing are substantially constant. In an exemplary embodiment, the method further includes radially expanding and plastically deforming the overlapping portions of the second and third wellbore casings, and radially expanding and plastically the portion of the third wellbore casing that does not overlap with the second wellbore casing. In an exemplary embodiment, the inside diameters of the second wellbore casing and the third wellbore casing are substantially equal. In an exemplary embodiment, the inside diameters of the second wellbore casing and the third wellbore casing are substantially constant. In an exemplary embodiment, the method further includes radially expanding and plastically deforming the overlapping portions of the second and third wellbore casings, and radially expanding and plastically the portion of the third wellbore casing that does not overlap with the second wellbore casing. In an exemplary embodiment, the inside diameters of the first, second, and third wellbore casings are substantially equal. In an exemplary embodiment, the inside diameters of the first, second, and third wellbore casings are substantially constant.

[0026] A system for forming a wellbore casing within a borehole that traverses a subterranean formation has been described that includes means for positioning a first wellbore casing within and coupling the first wellbore casing to the borehole, means for positioning a second wellbore casing within

the borehole that overlaps with and is coupled to the first wellbore casing, means for positioning a tubular liner within the borehole that overlaps with and is coupled to at least a portion of the second wellbore casing, means for extending the length of the borehole, means for decoupling the tubular liner from the second wellbore casing and removing the tubular liner from the borehole, and means for positioning a third wellbore casing within the borehole that overlaps with and is coupled to the second wellbore casing. In an exemplary embodiment, the system further includes means for radially expanding and plastically deforming the overlapping portions of the first and second wellbore casings, and means for radially expanding and plastically the portion of the second wellbore casing that does not overlap with the first wellbore casing. In an exemplary embodiment, the inside diameters of the first wellbore casing and the second wellbore casing are substantially equal. In an exemplary embodiment, the inside diameters of the first wellbore casing and the second wellbore casing are substantially constant. In an exemplary embodiment, the system further includes means for radially expanding and plastically deforming the overlapping portions of the second and third wellbore casings, and means for radially expanding and plastically the portion of the third wellbore casing that does not overlap with the second wellbore casing. In an exemplary embodiment, the inside diameters of the second wellbore casing and the third wellbore casing are substantially equal. In an exemplary embodiment, the inside diameters of the second wellbore casing and the third wellbore casing are substantially constant. In an exemplary embodiment, the system further includes means for radially expanding and plastically deforming the overlapping portions of the second and third wellbore casings, and means for radially expanding and plastically the portion of the third wellbore casing that does not overlap with the second wellbore casing. In an exemplary embodiment, the inside diameters of the first, second, and third wellbore casings are substantially equal. In an exemplary embodiment, the inside diameters of the first, second, and third wellbore casings are substantially constant.

[0027] It is understood that variations may be made in the foregoing without departing from the scope of the invention. For example, the teachings of the present illustrative embodiments may be used to provide a wellbore casing, a pipeline, or a structural support. Furthermore, the elements and teachings of the various illustrative embodiments may be combined in whole or in part in some or all of the illustrative embodiments.

[0028] Although illustrative embodiments of the invention have been shown and described, a wide range of modification, changes and substitution is contemplated in the foregoing disclosure. In some instances, some features of the present invention may be employed without a corresponding use of the other features. Accordingly, it is appropriate that the appended claims be construed broadly and in a manner consistent with the scope of the invention.

Claims

What is claimed is:

1. A method of forming a wellbore casing within a borehole that traverses a subterranean formation, comprising:
 - positioning a first wellbore casing within and coupling the first wellbore casing to the borehole;
 - positioning a second wellbore casing within the borehole that overlaps with and is coupled to the first wellbore casing;
 - positioning a tubular liner within the borehole that overlaps with and is coupled to at least a portion of the second wellbore casing;
 - extending the length of the borehole;
 - decoupling the tubular liner from the second wellbore casing and removing the tubular liner from the borehole; and
 - positioning a third wellbore casing within the borehole that overlaps with and is coupled to the second wellbore casing.
2. The method of claim 1, further comprising:
 - radially expanding and plastically deforming the overlapping portions of the first and second wellbore casings; and
 - radially expanding and plastically the portion of the second wellbore casing that does not overlap with the first wellbore casing.
3. The method of claim 2, wherein the inside diameters of the first wellbore casing and the second wellbore casing are substantially equal.
4. The method of claim 3, wherein the inside diameters of the first wellbore casing and the second wellbore casing are substantially constant.
5. The method of claim 1, further comprising:
 - radially expanding and plastically deforming the overlapping portions of the second and third wellbore casings; and
 - radially expanding and plastically the portion of the third wellbore casing that does not overlap with the second wellbore casing.

6. The method of claim 5, wherein the inside diameters of the second wellbore casing and the third wellbore casing are substantially equal.
7. The method of claim 6, wherein the inside diameters of the second wellbore casing and the third wellbore casing are substantially constant.
8. The method of claim 2, further comprising:
 - radially expanding and plastically deforming the overlapping portions of the second and third wellbore casings; and
 - radially expanding and plastically the portion of the third wellbore casing that does not overlap with the second wellbore casing.
9. The method of claim 8, wherein the inside diameters of the first, second, and third wellbore casings are substantially equal.
10. The method of claim 9, wherein the inside diameters of the first, second, and third wellbore casings are substantially constant.
11. A system for forming a wellbore casing within a borehole that traverses a subterranean formation, comprising:
 - means for positioning a first wellbore casing within and coupling the first wellbore casing to the borehole;
 - means for positioning a second wellbore casing within the borehole that overlaps with and is coupled to the first wellbore casing;
 - means for positioning a tubular liner within the borehole that overlaps with and is coupled to at least a portion of the second wellbore casing;
 - means for extending the length of the borehole;
 - means for decoupling the tubular liner from the second wellbore casing and removing the tubular liner from the borehole; and
 - means for positioning a third wellbore casing within the borehole that overlaps with and is coupled to the second wellbore casing.
12. The system of claim 11, further comprising:
 - means for radially expanding and plastically deforming the overlapping portions of the first and second wellbore casings; and

means for radially expanding and plastically the portion of the second wellbore casing that does not overlap with the first wellbore casing.

13. The system of claim 12, wherein the inside diameters of the first wellbore casing and the second wellbore casing are substantially equal.
14. The system of claim 13, wherein the inside diameters of the first wellbore casing and the second wellbore casing are substantially constant.
15. The system of claim 11, further comprising:
means for radially expanding and plastically deforming the overlapping portions of the second and third wellbore casings; and
means for radially expanding and plastically the portion of the third wellbore casing that does not overlap with the second wellbore casing.
16. The system of claim 15, wherein the inside diameters of the second wellbore casing and the third wellbore casing are substantially equal.
17. The system of claim 16, wherein the inside diameters of the second wellbore casing and the third wellbore casing are substantially constant.
18. The system of claim 12, further comprising:
means for radially expanding and plastically deforming the overlapping portions of the second and third wellbore casings; and
means for radially expanding and plastically the portion of the third wellbore casing that does not overlap with the second wellbore casing.
19. The system of claim 18, wherein the inside diameters of the first, second, and third wellbore casings are substantially equal.
20. The system of claim 19, wherein the inside diameters of the first, second, and third wellbore casings are substantially constant.

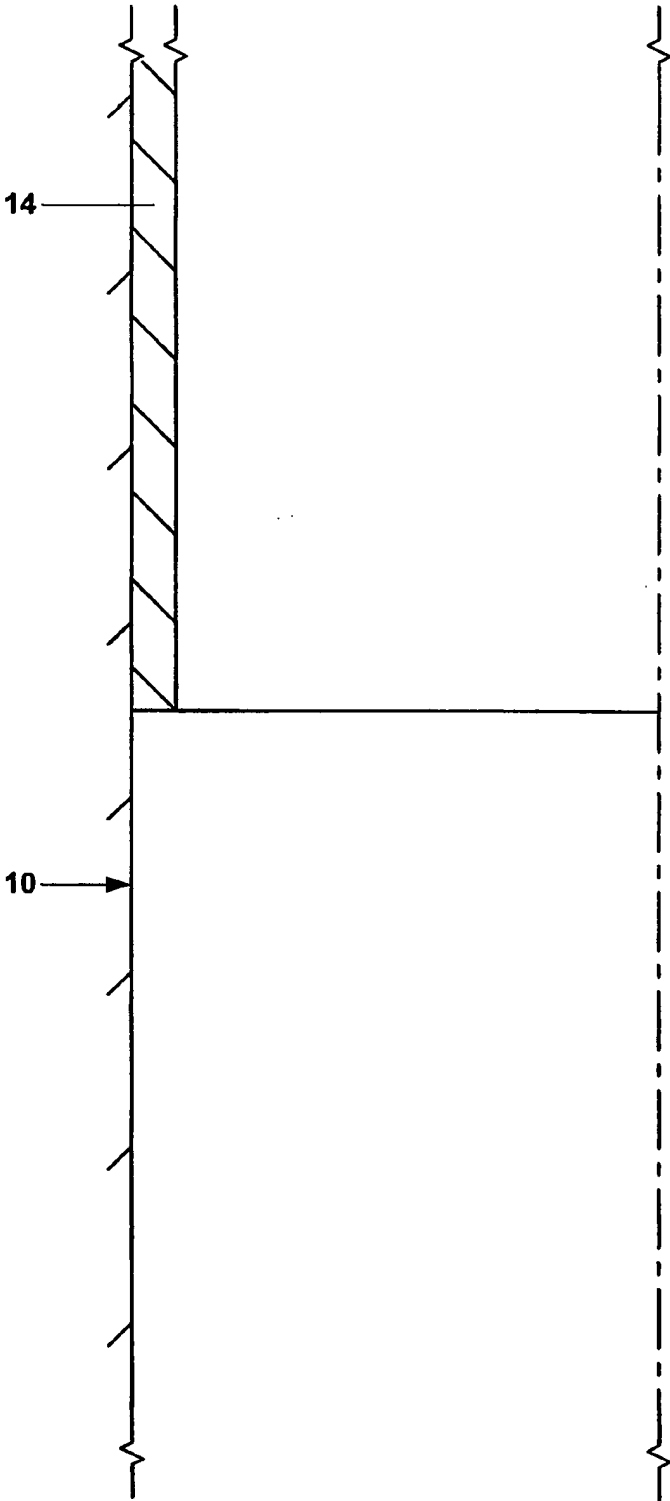

Fig. 1

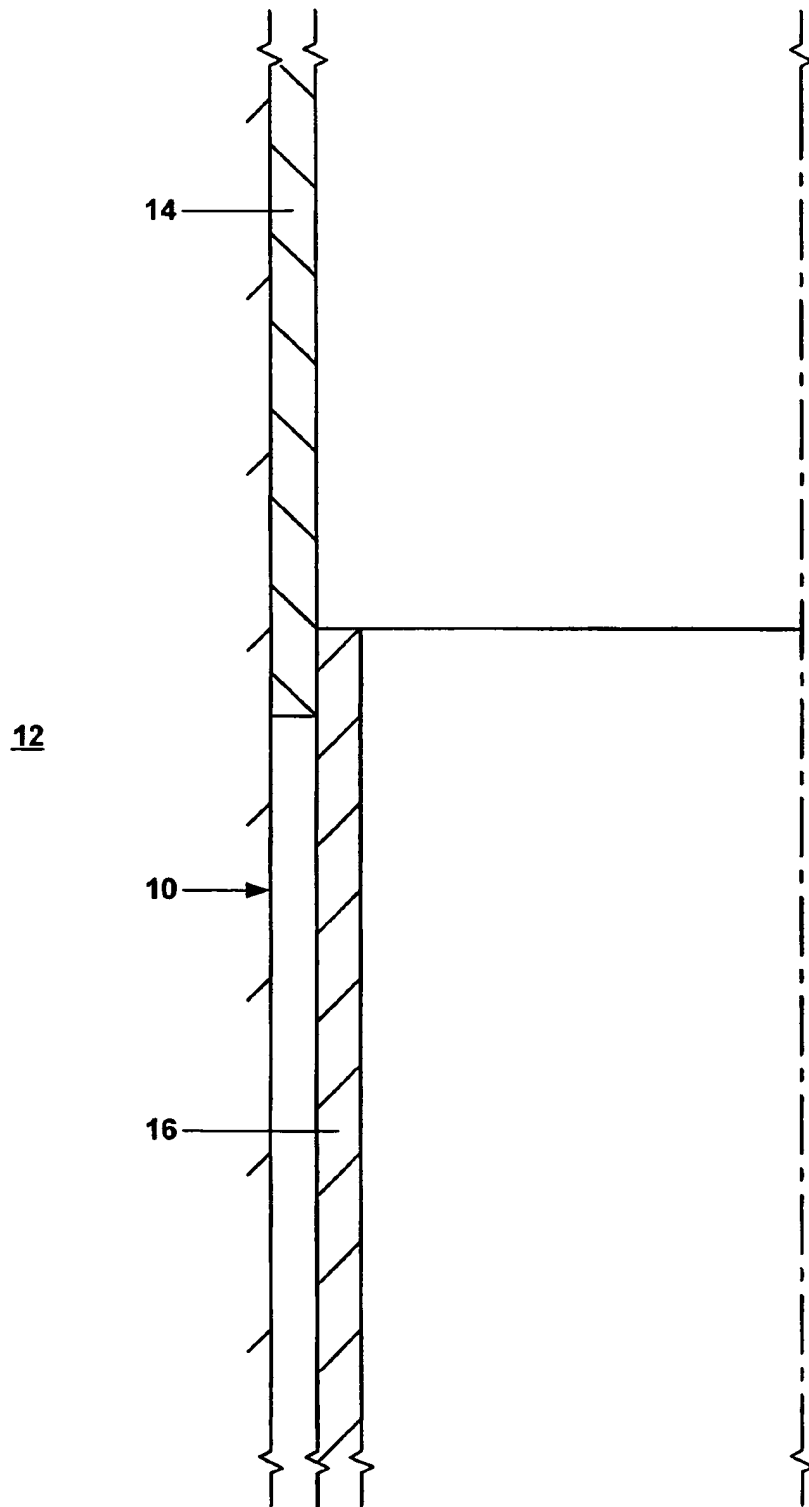

Fig. 2

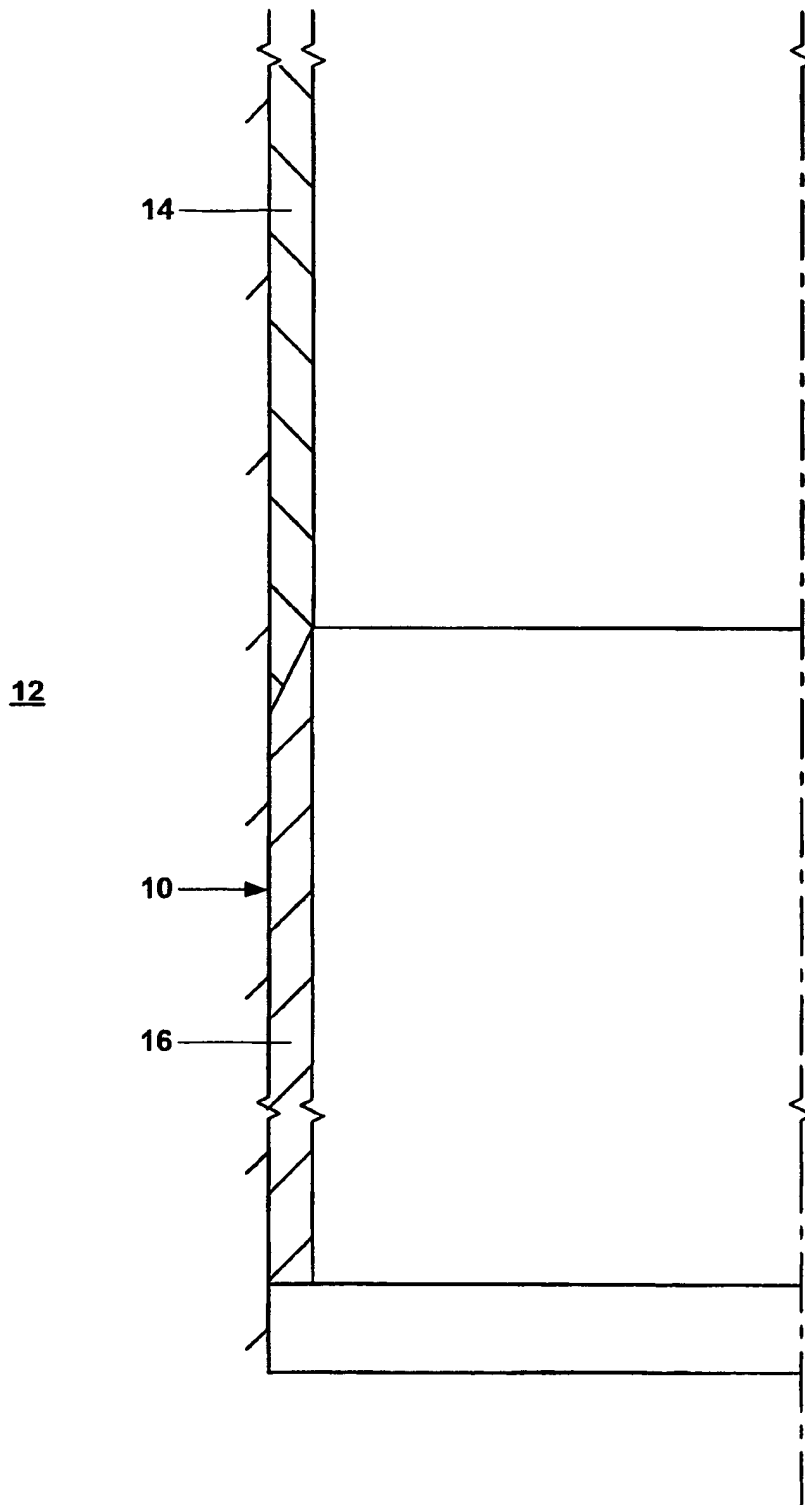

Fig. 3

12

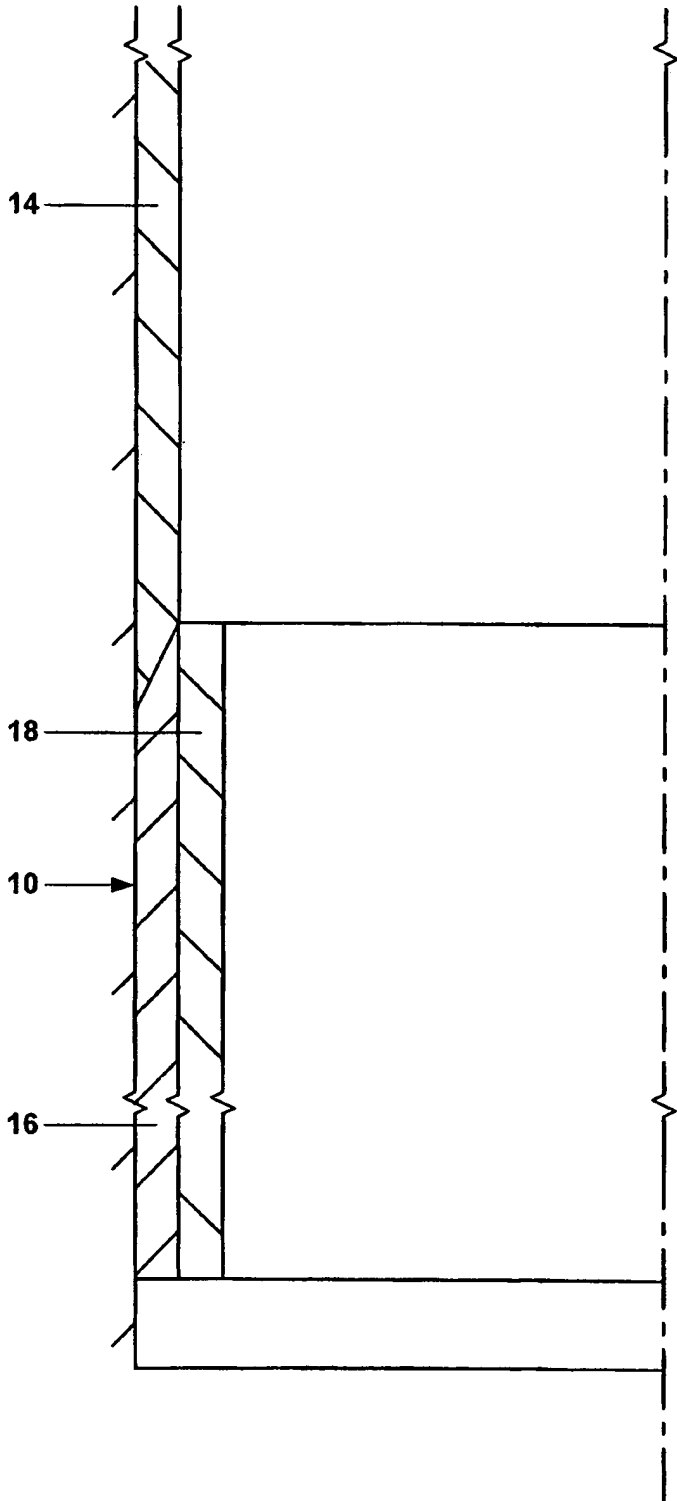

Fig. 4

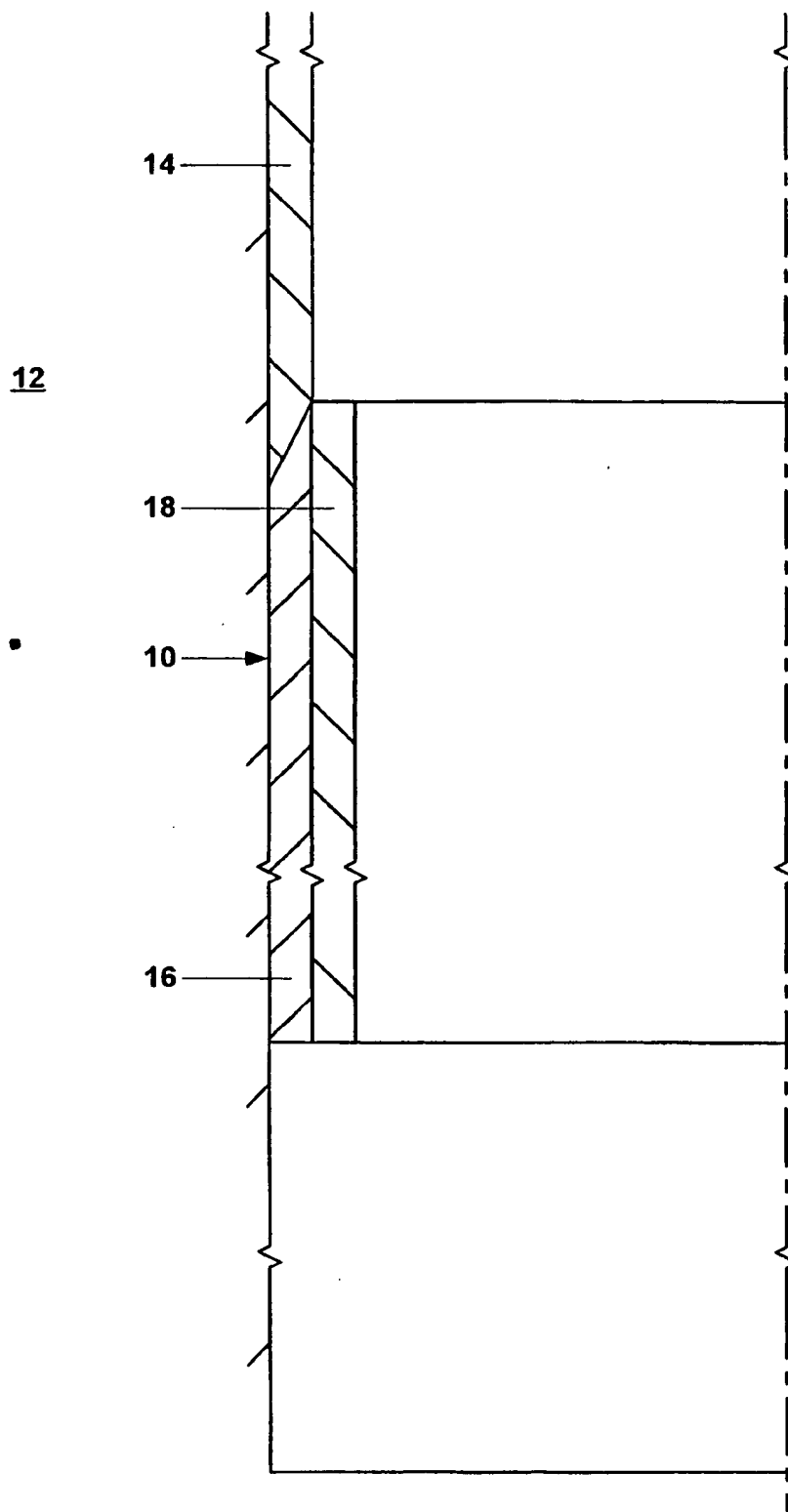

Fig. 5

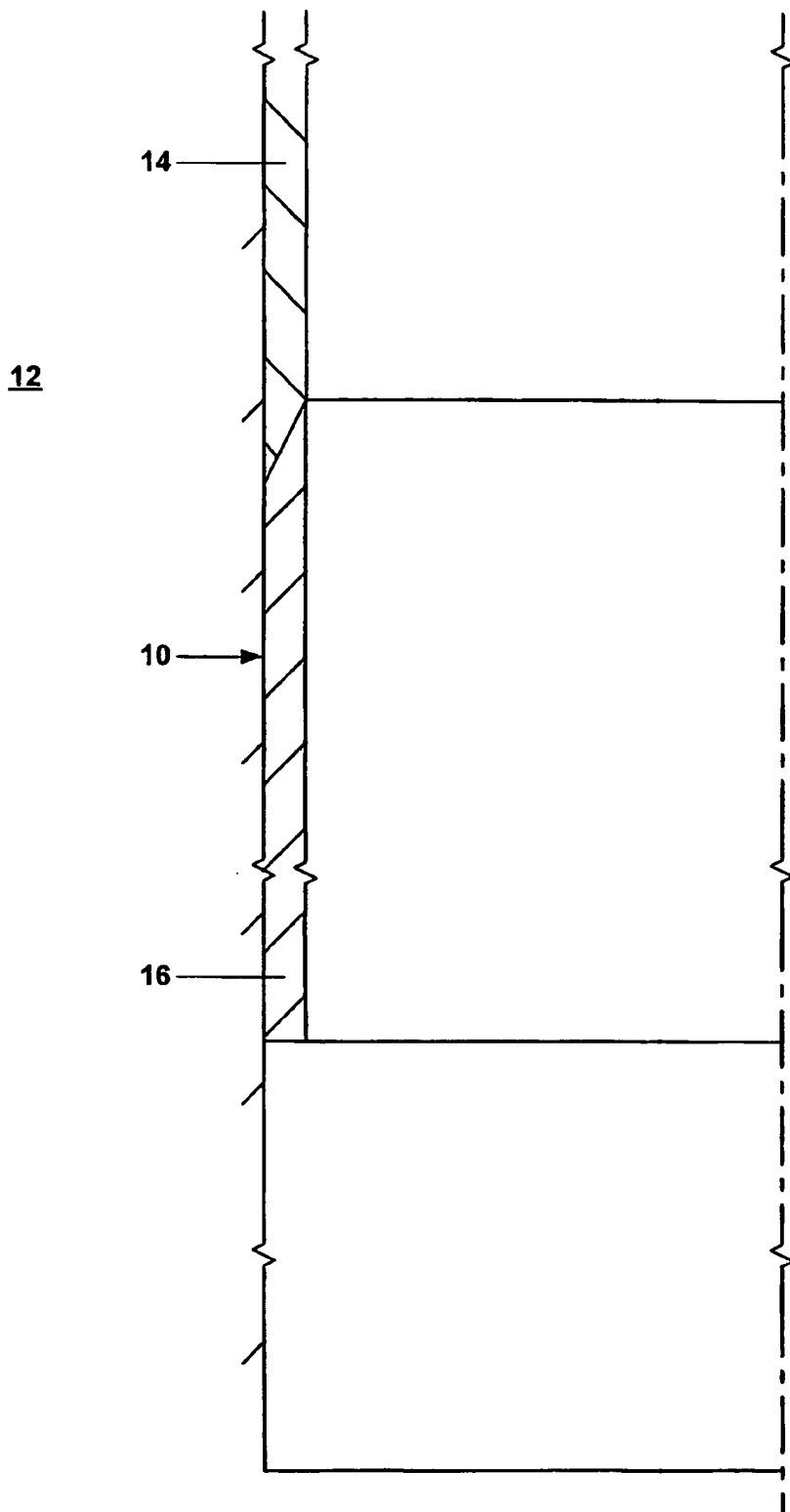

Fig. 6

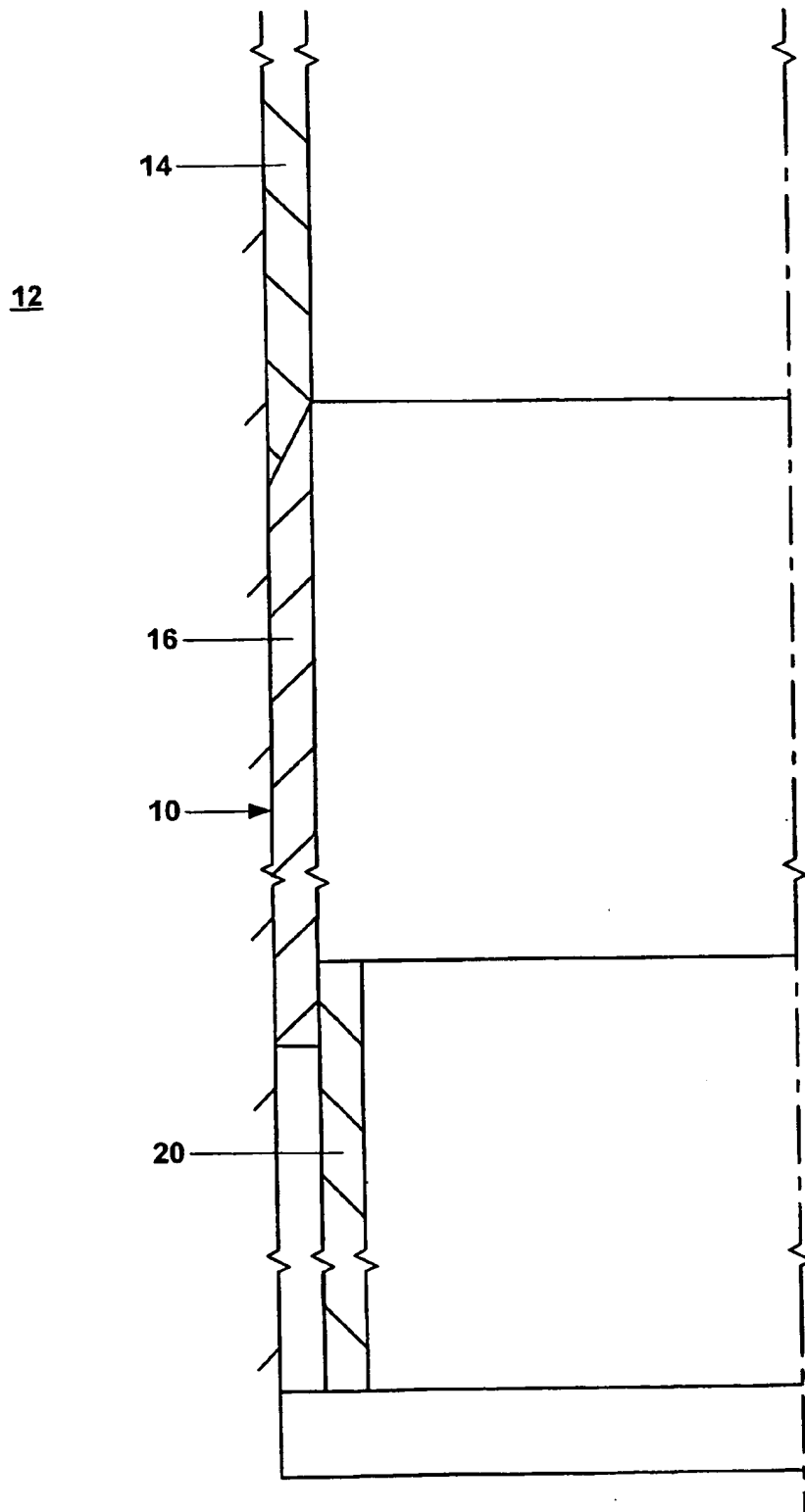

Fig. 7